

AZOL

CONSERVE WATER, CONSERVE LIFE

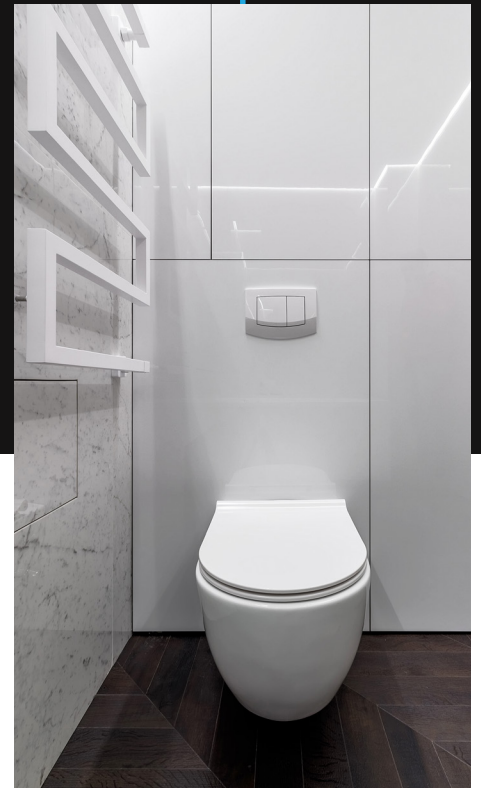

CONCEALED CISTERNS
PRODUCT CATALOG



Arden ME Trading LLC

AN INDUSTRY LEADER

With more than ten years of experience in the MEP department, Malik Group was initiated by Altamash Malik in 2021. After working with Morris Group International for a lengthy period, he decided to go his own way and hence became the CEO and Founder of Malik Group.

Considering his knowledge and network reach throughout the Middle East, North Africa, Central and South-East Asia, he learned the trade of the MEP division fairly quickly. Being continually proactive in the market has led Altamash to make sales a craft in his profession. Altamash regularly thrives on winning every single project in the region wherever his products are specified.



Arden ME Trading LLC

CONTACT US



+971543999944



+97145473991



altamash@malikgroup.me



**Floor 3P, Office 0202,
Tower A, Empire Heights,
Business Bay, Dubai, UAE**

FLUSH 95

Designed in Dubai
Made in Turkey
Low Cost
10 Year Warranty

Manufactured in Pinar Caddesi No: 72 Pinarbasi Izmir where quality control, quality assurance and testing takes place before being shipped off to its final destination.

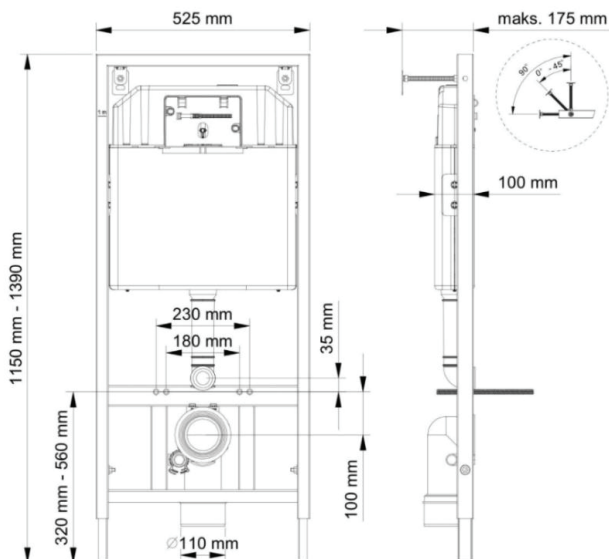

SPECIFICATION

Complies with the specifications of EN 14055 CL I-7-NL I VR II.

Features a discharge volume of 3/6 L, making it ideal for dry wall and brick wall installations.

Completely preassembled in the factory, ensuring ease of installation.

Boasts a maximum water tank capacity of 10 L, with a tank depth of 80 mm (overall thickness including frame 100 mm).

Equipped with a mechanical dual flush system for efficient water use.

Water supply connection located at the top right, with a G 1/2 male connection.

Meets acoustic class 1st Class EN 14124 for the inlet valve.

Capable of handling water flow pressure of 0.3 MPa (3 bar) and a maximum volume of 9.0 dB, with a flow rate of 9 L/min.

Constructed with an impact copolymer special PP body, providing high resistance to impact and thermal shock.

Features a powder-coated tubing profile thick metal frame (30 mm x 40 mm).

Comes with a 10-year warranty for added peace of mind.

WC hanging rods can bear up to 400 KGs, with adjustable distances of 18 or 23 cm between toilet bowls.

PLATES



Colours and finish can be customised upon order placement, customer will have to provide the exact RAL number.



Arden ME Trading LLC

AZOL

CONSERVE WATER, CONSERVE LIFE



PLATES

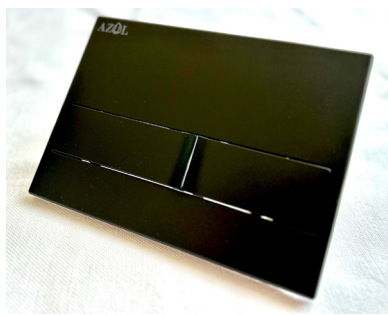
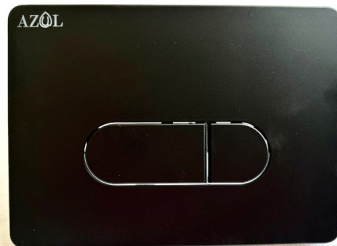

Olympos Plate Datasheet



SPECIFICATION

Dual Flush
Chrome OR Matt Finish
Mechanical Buttons

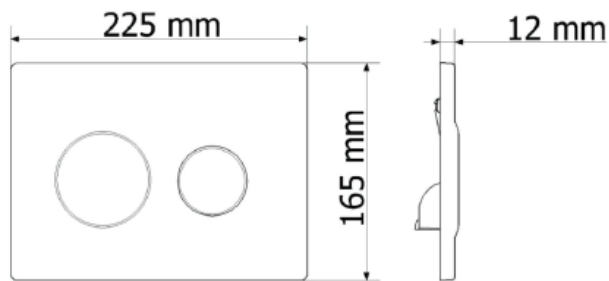

Karina Plate Datasheet



SPECIFICATION

Dual Flush
Chrome OR Matt Finish
Mechanical Buttons

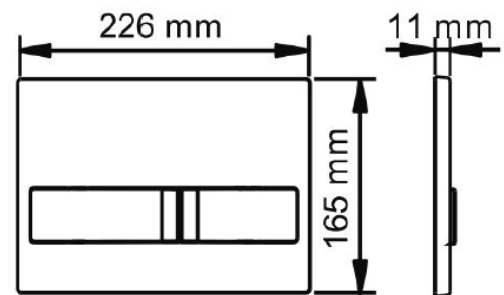

AZOL

CONSERVE WATER, CONSERVE LIFE



Mia Plate Datasheet

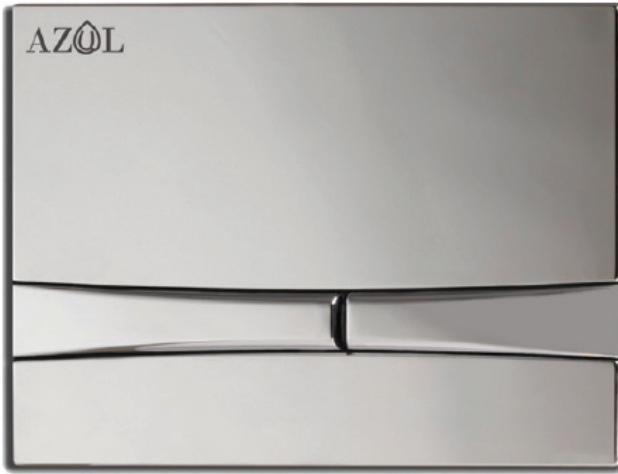

SPECIFICATION

Dual Flush
Chrome OR Matt Finish
Mechanical Buttons

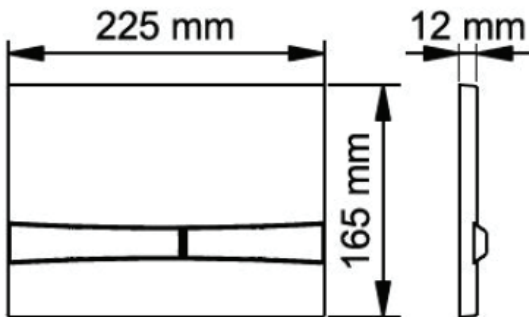

Siena Plate Datasheet

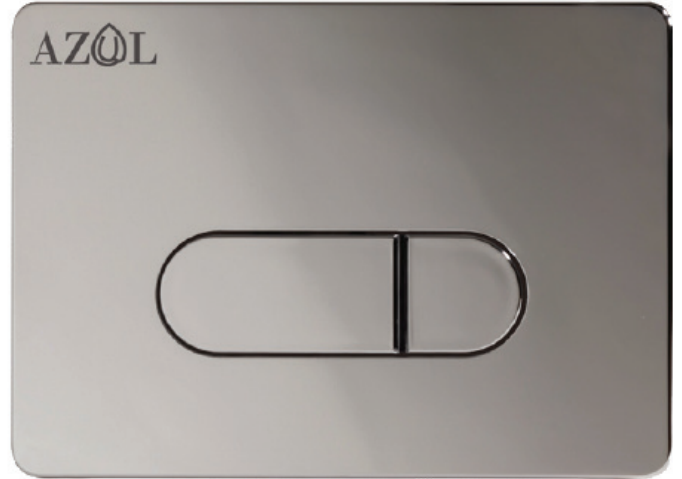

SPECIFICATION

Dual Flush
Chrome OR Matt Finish
Mechanical Buttons

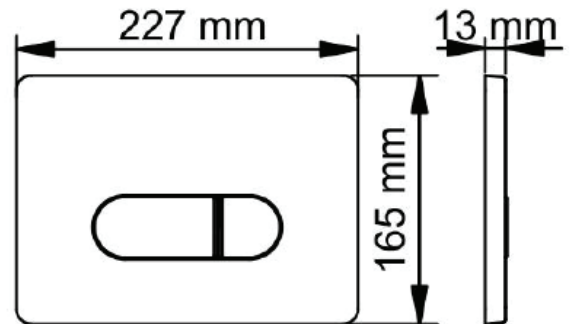

AZOL

CONSERVE WATER, CONSERVE LIFE



SAN 140



SPECIFICATION

Dual Flush Concealed Tank
3/6 Litre Dual Flush
Easy Installation
10 Year Warranty
Silent Fitting
Operating Pressure is between 1 – 7 bar
Weight limit 400 KG
Galvanised Steel Tubular Frame
Made of Polyethylene, 3 mm thickness

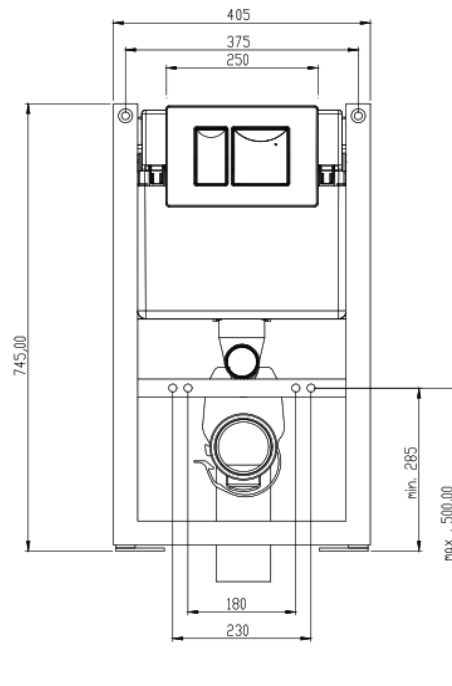

AZOL

CONSERVE WATER, CONSERVE LIFE





Azul WC 1010



SPECIFICATION

The body material is made from ceramic. Comes with a 10-year warranty for added peace of mind.

Completely preassembled in the factory, ensuring ease of installation.

Rimless Bowl Design, the absence of an inner rim makes the bowl much easier to clean and maintain.

The cover material is made of UF, has a 5-year warranty.

CE Certified.

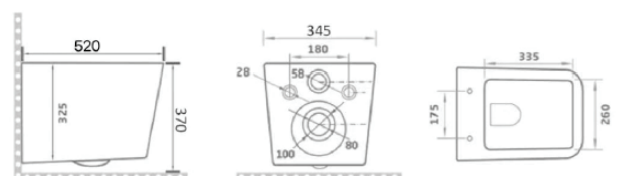



Azul WC 1020



SPECIFICATION

The body material is made from ceramic. Comes with a 10-year warranty for added peace of mind.

Completely preassembled in the factory, ensuring ease of installation.

Rimless Bowl Design, the absence of an inner rim makes the bowl much easier to clean and maintain.

The cover material is made of UF, has a 5-year warranty. CE Certified.

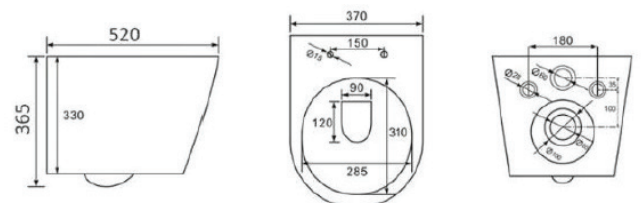



Azul WC 1030



SPECIFICATION

The body material is made from ceramic. Comes with a 10-year warranty for added peace of mind.

Completely preassembled in the factory, ensuring ease of installation.



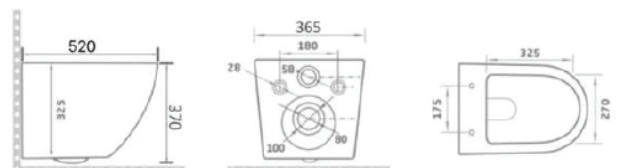

Rimless Bowl Design, the absence of an inner rim makes the bowl much easier to clean and maintain.

The cover material is made of UF, has a 5-year warranty. CE Certified.



AZOL

CONTACT US

-  +971543999944
-  +97145473991
-  altamash@malikgroup.me
-  Floor 3P, Office 0202,
Tower A, Empire Heights,
Business Bay, Dubai, UAE



Arden ME Trading LLC